



Part #977

1-31-2012

NOTE: If your car came with a factory rear anti-sway bar, the new bar can be mounted using the factory hangers if desired, and most of the installation steps can be eliminated. The new bar should be installed using the new bushings and brackets provided. If your car did not come with a factory bar, follow all of the steps below.

Step 1. Using the frame brackets as a template, align the forward hole of the bracket with the forward of the two existing holes in the frame bottom above the rear of the axle. Mark the frame through the brackets rear hole. Drill the frame with a 3/8" drill bit. For your safety always use caution and wear eye protection when drilling.

Step 2. Assemble the hanger bolts as shown and tighten the lock-nut until the bushings are mildly compressed. Cut off any excess threads. Place two D-bushing on the bar as shown.

Step 3. Start a nut on one leg of the U-bolt and insert the other leg through one hole in the frame. Maneuver the U-bolt until the other leg drops out of the other hole. Remove the nut and install the hanger assembly onto it. Secure the hangers with the lock-nuts provided. Tighten to 10 lb/ft.

Step 4 Support the rear axle under the spring plates. Remove the bottom inner nuts from the bolts that connect the spring to the spring plate. Using the bar brackets with the 7/16" holes, engage the brackets with the bolts on the spring plates to secure the ends of the bar. Replace the nuts and tighten to 35 lbs./ft.

Step 5. Check all fasteners for suitable tightness. Have someone bounce the rear end of the car and check that all parts have clearance throughout the suspension travel. Road test your car to familiarize yourself with its new handling. As we cannot supervise your installation or driving, we cannot be held responsible for more than the cost of the kit. For best balance, control and stability, this kit should be used in conjunction with our front kits.

Hardware

4- RH 612W	Bushings	2- RH 327	Locknuts
2- RH 046W	Brackets	2- RH 079	Clevis
2- RH 199	Bolts	4- RH 214	Bolt
2- RH 402	U-Bolts	8- RH 304	Lock-nuts
2- RH 610	Drop Links	2- RH 043B	Brackets

Direction 681/977

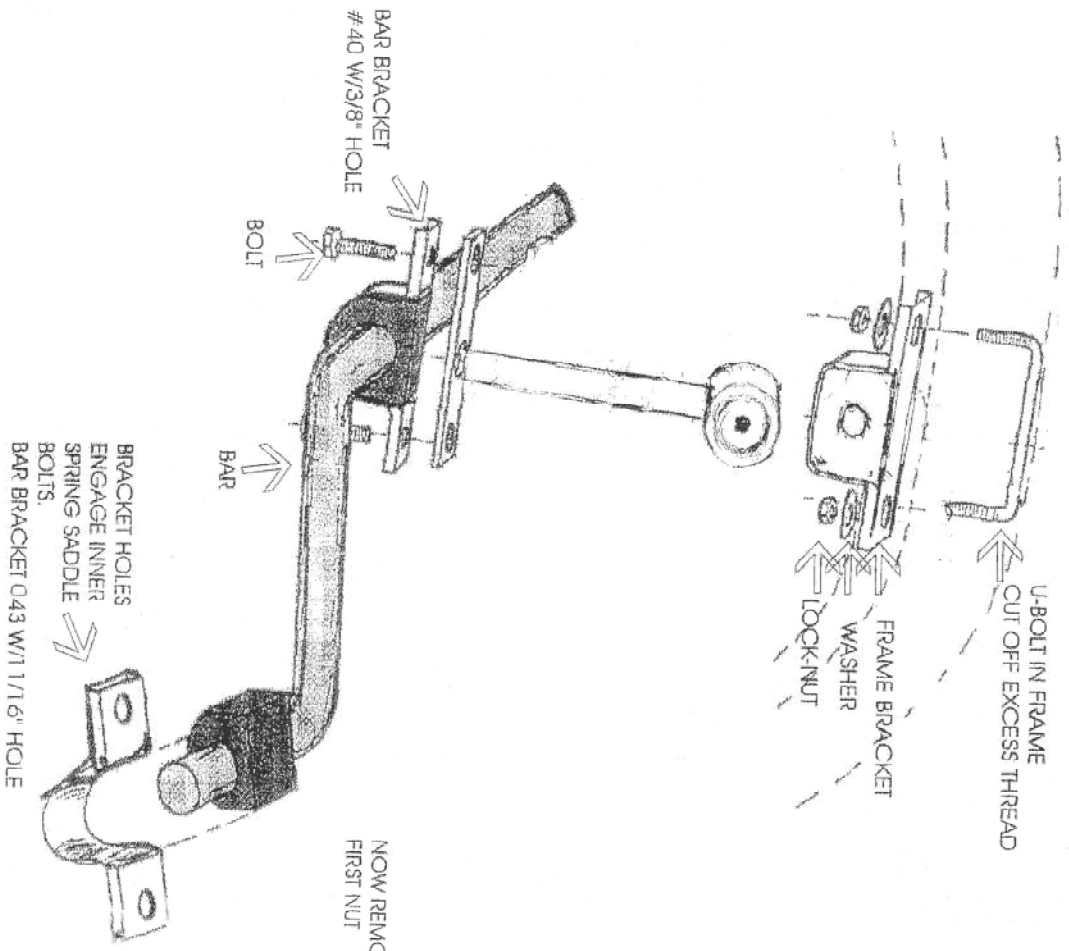

HOW TO INSTALL A 402 U-BOLT

