



Part #157

- Step #1.** Assemble the end-link as illustrated so as to connect the bar eye and the angle bracket. The angle bracket and/or the whole end-link assembly may be put together the other way up if better alignment is attained for the particular height of your car's frames relative to the A-arms. The bar eye may thus be below the angle bracket or it may be as illustrated, but with the angle the other way up.
- Step #2.** Position the bar so the angle brackets locate on the front of the A-arms. With the bar centered on the car, mark through the angle bracket and drill the front side of the A-arm with a 3/8" drill bit. On some custom installations, the bar can be located further to the rear on the frames so that the eye is over the A-arm stamping. In this case drill a 5/8" hole directly in the A-arm to take the end-link and discard the angle bracket.
- Step #3.** For convenience, tie the mid-section of the bar up against the frames and connect the end-link assemblies to the A-arms. The bar bushings should be in place on the bar against the frames. Cover the bushings with the bar bracket and mark the frames through the holes. Drill with a 3/8" drill bit.
- Step #4.** Place a lock nut on one end of the U-bolt and insert the other end through the end of the frame bracket and then cover with the free end of the bracket and secure with the other lock-nut so as to hold the mid-section bushing in place.
- Step #5.** Check all fastenings for suitable tightness. Have someone bounce the front of the car so you may check clearance throughout suspension travel distance. Road test the car so as to familiarize yourself with the car's new handling. As we cannot supervise your installation or driving, we cannot be held responsible for more than the cost of the kit. **Note:** For best results and most balanced cornering, this kit should be used in conjunction with our rear kit. Please consult stock list for application.

HARDWARE

2	RH 015	End-Links
2	RH 508	Bushings
2	RH 040	Brackets
2	RH 022	Angle Brackets
2	RH 402	U-Bolts
2	RH 213	Bolts
6	RH 304	Lock-Nuts
2	RH 102	Washers

DIRECTION 157

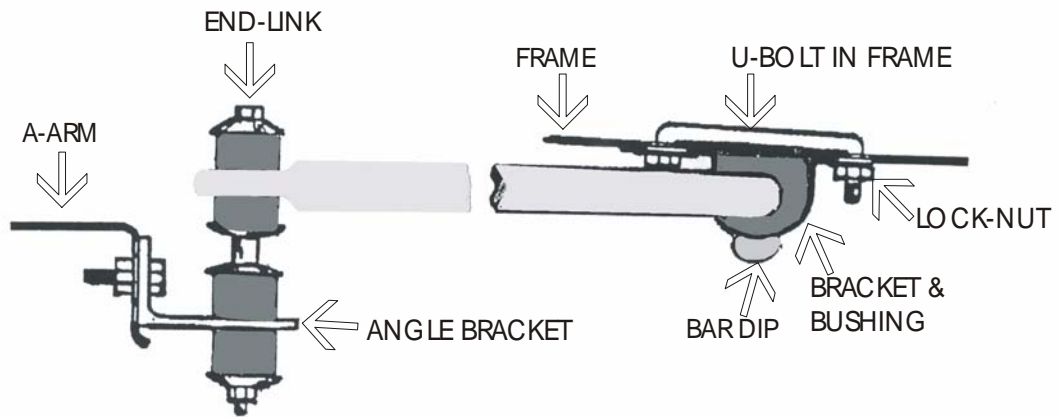

HOW TO INSTALL A 402 U-BOLT IN FRAME

