



Part #991

8-23-2005

- Step 1.** Hang the U-bolts around the axle. Raise up the slotted plates under the U-bolt so as to engage the U-bolt legs. Follow with the bar bracket that should already be around under the bar. Start the nuts. Place the D-shaped rubber bushings on the bar near the bends, flat side up. Next, slide the loosely assembled U-bolt and bracket assembly down the axle so that the bracket is around the rubber bushing. Insert the locking device from the side, with the legs toward the axle. Center it on the slotted plate.
- Step 2.** Assemble the end-links as illustrated. Pass the end-links center bolt through one washer, through a rubber bushing, through the frame bracket (from inside it), through another bushing; another washer; the tube spacer; another washer; another bushing; the bar eye; another bushing; the last washer; and secure with a lock-nut. Be sure the washers have the or hollow side towards the rubber bushing and that the rubber bushings have the ends of the stepped surface towards the bracket or bar eye. Tighten the lock-nuts, so the assembly is securely snug, but not so tight that the bushings bulge to a noticeable extent.
- Step 3.** The bar should be positioned so that the mid-section runs below and to the rear of the rear axle with the arms facing to the rear, and the dip down, or on the alternate position (for vehicles with higher ride height or where clearance problems are encountered) the bar mid-section runs along the top rear of the axle with the dip up. It will pass just below and to the rear of the brake junction fitting bar forward of any shocks mounted to the rear of the axle.
- Step 4.** Position bar so that the forges are horizontal and the axle clamp assembly, holding the bar mid-section is tilted slightly to the rear of the axle, with the car resting naturally on its springs on level ground, the frame brackets should position themselves so as to align with the bottom of the frames. Adjust the bar position relative to the axle if needed.
- Step 5.** Mark through the frame bracket holes. Drill one hole with a 3/8" drill bit. Use the square U-bolt to get the exact spacing for the second hole and drill it.
- Step 6.** Place a lock-nut on one leg of the square U-bolt and insert the other end into one of the drilled hole. Maneuver it until reappears through the other drilled hole. Place one end of the base plate and the frame bracket over the leg and start another lock-nut on it. Remove the first nut, and position the free end of the plate and bracket over the U-bolt leg and replace the nut.
- Step 7.** Have someone bounce the rear of the car so you can check that all parts of the bar and hardware clear throughout the suspension and travel distance. (But don't be under the car when it is bounced). If rubber stops are visible, measure the maximum travel distance so you can better estimate clearances. If all is clear, tighten nuts on frame and axle.
- Step 8.** Road test the care to familiarize yourself with its new handling. As we cannot supervise your installation or driving we cannot be responsible for more than the cost of the kit.

Hardware:

2 RH 014	End-Links	4 RH 104	Washers
8 RH 304	Lock-Nuts	2 RH 407	U-Bolts
2 RH 041	Brackets	2 RH 055	Locking Device
2 RH 031	Base Plates	2 RH 510	Bushings
2 RH 402	Square U-Bolts	2 RH 046	Brackets

DIRECTION 991

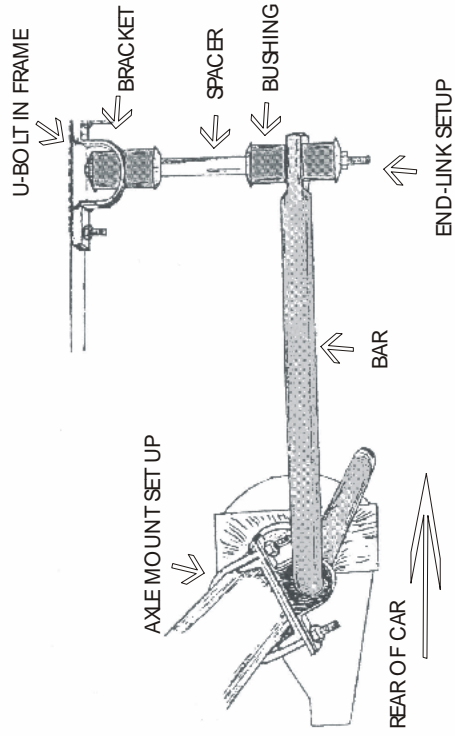

ALTERNATE INSTALLATION

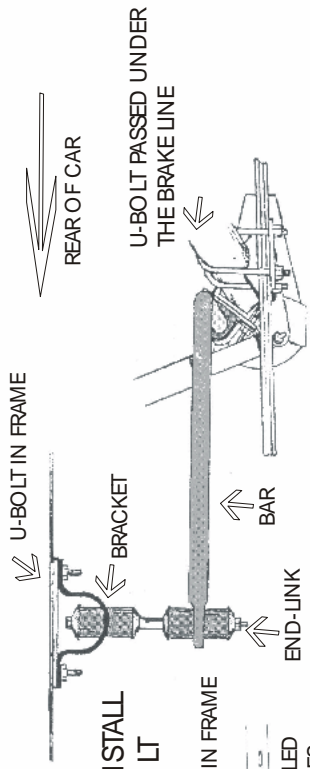

HOW TO INSTALL A 402 U-BOLT



NOW REMOVE FIRST NUT
BRACKET