



Part #390

8-18-2005

- Step 1.** The bar should be positioned so that the mid-section runs under the rear axle with arms facing forward and dip down, to the rear.
- Step 2.** Hang the U-bolts around the axle. Raise up the slotted plates under the U-bolt then engage the U-bolt legs. Follow with the bar bracket that should already be around the bar. Start the nuts. Place the mid-section bushings on the bar near the bends, flat side up. Next, slide the loosely assembled U-bolt and bracket assembly down the axle so that the bracket is around the rubber bushing. Inset the locking device from side with the legs toward the axle, and center it on the slotted plate.
- Step 3.** Assemble the end-links as illustrated. Tighten the lock-nuts, so the assembly is secure, but not so tight that the bushings bulge to a noticeable extent.
- Step 4.** Position the bar so that the forges are positional and the axle clamp assembly is holding the bar midsection below the axle. With the car resting naturally on its springs, on level ground, the frame brackets should position themselves to align with the frame bottom. Adjust the bar position relative to the axle if needed.
- Step 5.** Mark through the frame bracket holes for drilling. Drill one hole with a 3/8" drill bit. Use the square U-bolt to get the exact spacing for the second hole and drill it.
- Step 6.** Place a lock-nut on one leg of the square U-bolt and insert the other end into one of the drilled holes. Maneuver it until reappears through the other drilled hole. Place one end of the base plate and the frame bracket over the leg and start another lock-nut on it. Remove the first nut, and position the free end of the plate and bracket over the U-bolt leg and replace the nut.
- Step 7.** Have someone bounce the rear of the car so you can check that all parts of the bar and hardware clear throughout the suspension and travel distance. If all is clear, tighten all the nuts on the assemblies.
- Step 8.** Road test the car to familiarize yourself with its new handling. As we cannot supervise your installation or driving we cannot be responsible for more than the cost of the kit.

NOTE: For the best balance, control and stability, this kit should be used in conjunction with our front bar kit in one inch diameter.

Hardware:

2 RH 015	End-Links	2 RH 610B	Bushings
2 RH 046H	Brackets	2RH 044	Brackets
2 RH 055	Brackets	2 RH 031	Base Plates
2 RH 407	U-Bolts	2 RH 402	U-Bolts
8 RH 304	Lock-Nuts		

Part # 390

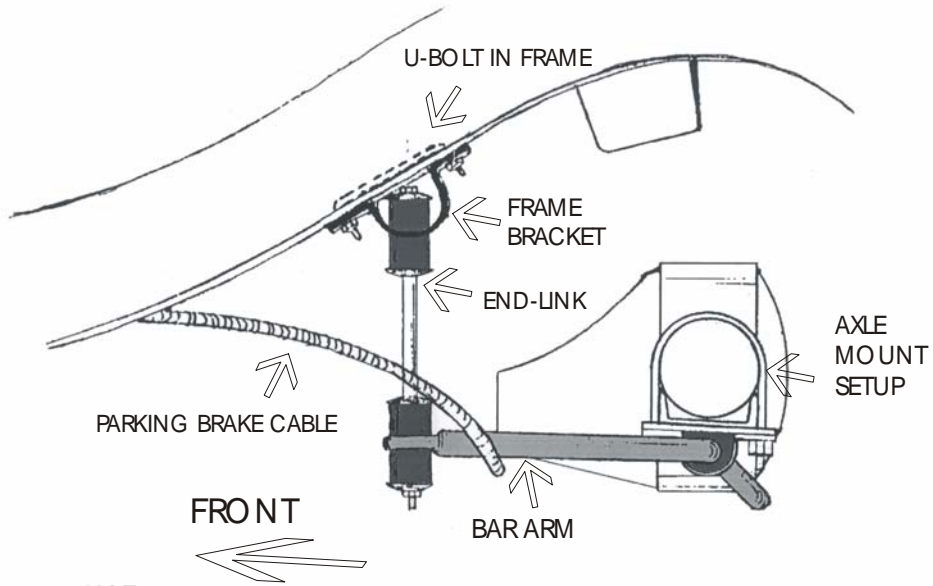

AXLE MOUNT SETUP

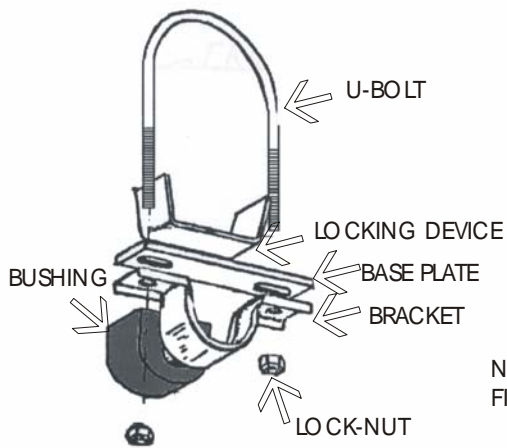

HOW TO INSTALL A 402 U-BOLT

